



Robots, élèves, enseignants, quelle intelligence partagée ? RNRE 2018 Ifé - ENS de Lyon

Quelle valeur ajoutée à l'utilisation de drone en milieu scolaire ?

Ouissem Moussi, *enseignant de technologie*

Collège Colette 69800 Saint-Priest



Le drone au cœur de la révolution NUMÉRIQUE

SURVEILLER



Agriculture
Feux de forêts
Infrastructures
Etc...

INSPECTER



Ouvrages
Archéologie
Usines
Etc...

TRANSPORTER



Colis
Médicaments
Premiers secours
Etc...

INTERVENIR



Agriculture
Pollution
Sécheresse
Etc..

RELAYER



Actualité
Sites naturels
Télécommunications
Etc...

Le drone : un exemple des plus éloquent

Le drone : un objet pluri-technologique

Idéal comme support de cours



Le drone : une croissance vertigineuse



Hausse de 90 % de la
production mondiale
(source : prévisions cabinet Teal Group)



Prévisions 2020 :
10 000 drones aux USA
(contre 6600 avions de ligne
en 2013).

Le drone : au cœur des enjeux économiques

- - Multiplication des services rendus
- - Baisse des coûts d'exploitation
- - Grande rapidité d'action



Quelle valeur ajoutée à l'utilisation de drone en milieu scolaire ?

La motivation scolaire

Repérer et imaginer les métiers d'avenir

Donner du sens aux apprentissages

projets Interdisciplinaires

Quels nouveaux services pour demain ?

Questionner nos modèles actuels / Innover ?

Vulgariser les technologies de pointe ?

Décomposer l'objet drone en sous-ensembles ?



Quelle valeur ajoutée à l'utilisation de drone en milieu scolaire ?

Approche pédagogique Originale / Ludique / Motivante

Niveau 1 : **Dès le cycle 3 ----> cycle 4**



Programmation graphique



Drone aéroglesseur terrestre

Quelle valeur ajoutée à l'utilisation de drone en milieu scolaire ?

Approche pédagogique Originale / Ludique / Motivante

Niveau 1 : **Dès le cycle 3 ----> cycle 4**

- > Défi robotique
- > Travail groupe



```
on start
  take off
  wait 1 secs
  up for 1 seconds
  wait 1 secs
  forward for 2 seconds
  wait 1 secs
  turn right by 90 degrees
  wait 1 secs
  turn left by 45 degrees
  wait 1 secs
  land
```



Quelle valeur ajoutée à l'utilisation de drone en milieu scolaire ?

Approche pédagogique Originale / Ludique / Motivante

Niveau 2 : **Dès le cycle 4 ----> Lycée – Test rotation moteurs etc...**

> Aller au cœur de l'objet DRONE



Tests effectués
sans hélices

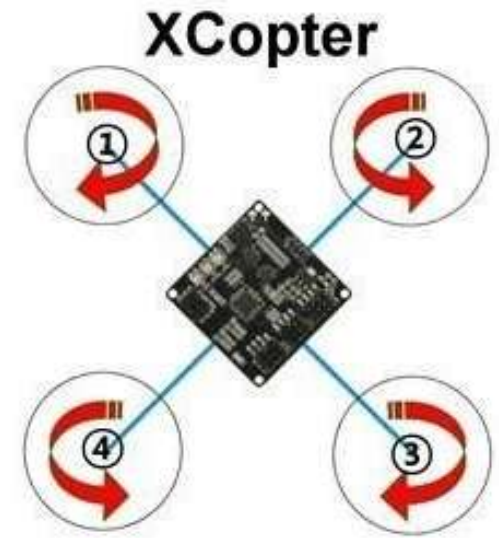

Quelle valeur ajoutée à l'utilisation de drone en milieu scolaire ?

Approche pédagogique Originale / Ludique / Motivante

Niveau 2 : Dès le cycle 4 ----> Lycée – VOL BASIQUE MANUEL

> Vol de mini-drones en Intérieur

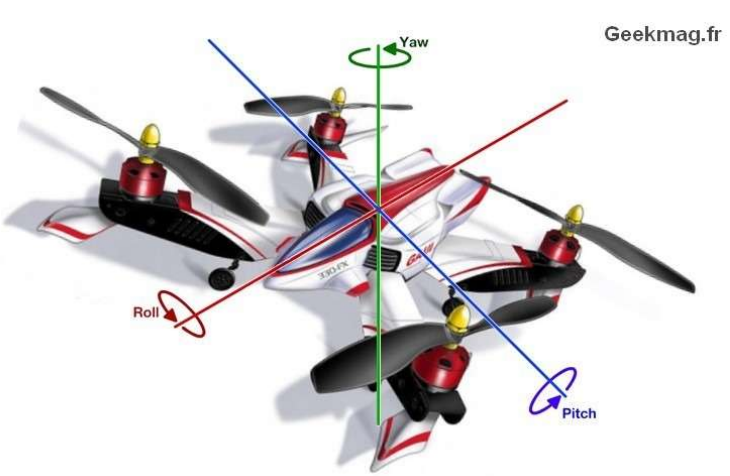
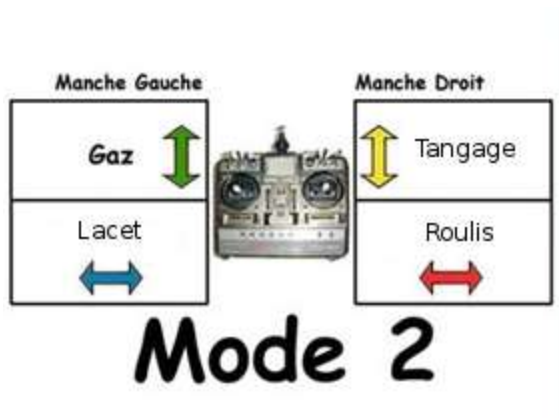

Quelle valeur ajoutée à l'utilisation de drone en milieu scolaire ?

> Découvrir les technologies performantes et libres

Contrôleur de vol
ARDUCOPTER

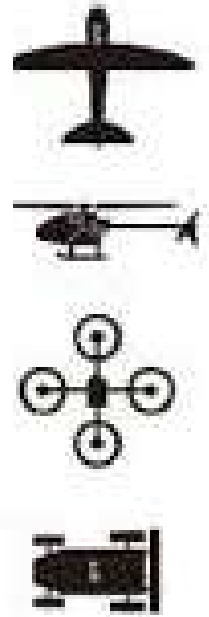

<http://ardupilot.org>

Quelle valeur ajoutée à l'utilisation de drone en milieu scolaire ?

> Découvrir les Logiciels de pilotage

Logiciel Mission
Planner



Quelle valeur ajoutée à l'utilisation de drone en milieu scolaire ?

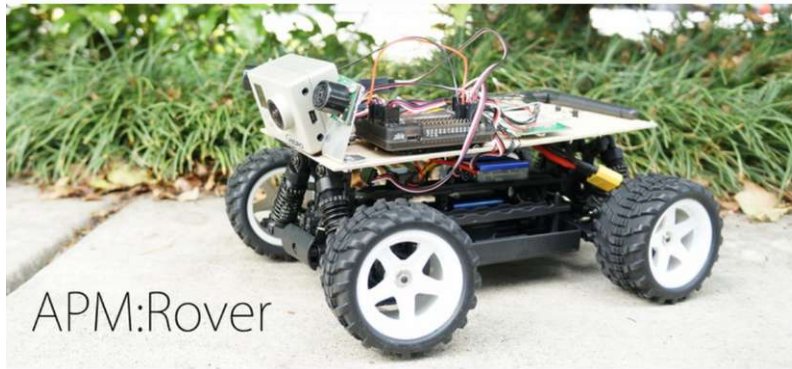

Drone terrestre 100 % sécurisé

Autopilot
Guidage GPS
Mission programmée
Téléométrie...



APM Planner 1.0.0 Build 1.0.4173.36295 By Michael Osborne

ArduPilotMega COM46 115200

Distance: 0.5663 Km
Prev: 367.63 m

1. Connect
2. Read WP's if you need to
3. Ensure your Home location and ALT is set
4. Click on the map to start adding WP's

Mouse Location
Lat: 37.87082211
Long: -122.3200714
Alt: 0

GoogleSatellite
Status: loaded files
Load WP File
Save WP File
Read WP's
Write WP's
Home Location
Lat: 37.87127945
Long: -122.3175930
Alt: 100

WP	Command	Delay	Alt	Lat	Long	Lock GE	Delete	Up	Down
2	WAYPOINT	I need ...	100	37.8721433	-122.3179471	<input checked="" type="checkbox"/>	X		
3	WAYPOINT	I need ...	100	37.8724651	-122.3166704	<input checked="" type="checkbox"/>	X		
4	WAYPOINT	I need ...	100	37.8716352	-122.3160160	<input checked="" type="checkbox"/>	X		

Quelle valeur ajoutée à l'utilisation de drone en milieu scolaire ?

> Zone de sécurité (GEOFENCE)

Des fonctionnalités réalistes



Quelle valeur ajoutée à l'utilisation de drone en milieu scolaire ?

Approche pédagogique Originale / Ludique / Motivante

> Cartographie aérienne : avec pilote professionnel



<http://calyptone.fr/>

Quelle valeur ajoutée à l'utilisation de drone en milieu scolaire ?

Approche pédagogique Originale / Ludique / Motivante

> Vol avec un pilote professionnel

Cartographie aérienne
Scan 3 D d'un château d'eau
Pilotage de drône
Découverte métiers
Sensibilisation législation
Post traitement informatique



Quelle valeur ajoutée à l'utilisation de drone en milieu scolaire ?

Après le vol > Post traitement Logiciel Informatique

Cartographie 2D

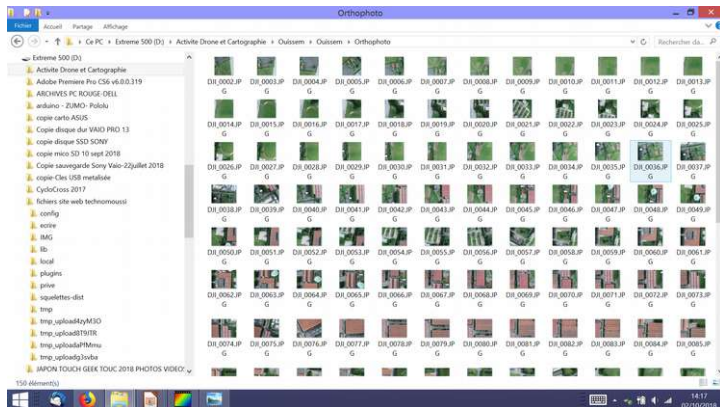

PhotoScan
3D Modeling and Mapping

Agisoft

Version d'essai
GRATUITE



<http://www.agisoft.com/>

Quelle valeur ajoutée à l'utilisation de drone en milieu scolaire ?

Approche pédagogique Originale / Ludique / Motivante

Photogrammétrie en collège sans drone ni pilote ? C'est possible !



+

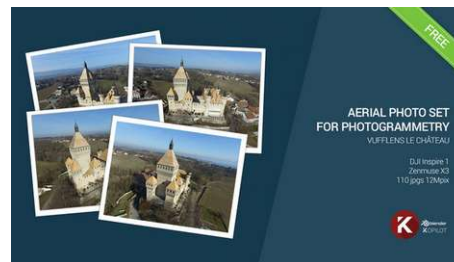

Le set de photos complet

Free Download



Le fichier .OBJ et sa texture UV

Free Download

<https://www.kopilot.ch/blender-blog-aerial-photogrammetry-experiment/>

<http://gregdesign.ch/prise-de-vue-aerienne-avec-un-drone-et-photogrammetrie-3d/>

<http://www.agisoft.com/>

Quelle valeur ajoutée à l'utilisation de drone en milieu scolaire ?

Photogrammétrie aérienne 3D d'un château

Télécharger les photos du vol du drone

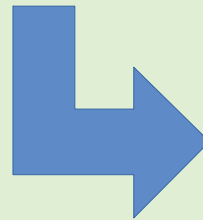

Nuage de points > Maillage 3D > Texture

Quelle valeur ajoutée à l'utilisation de drone en milieu scolaire ?

Approche pédagogique Originale / Ludique / Motivante

> Approche prototypage

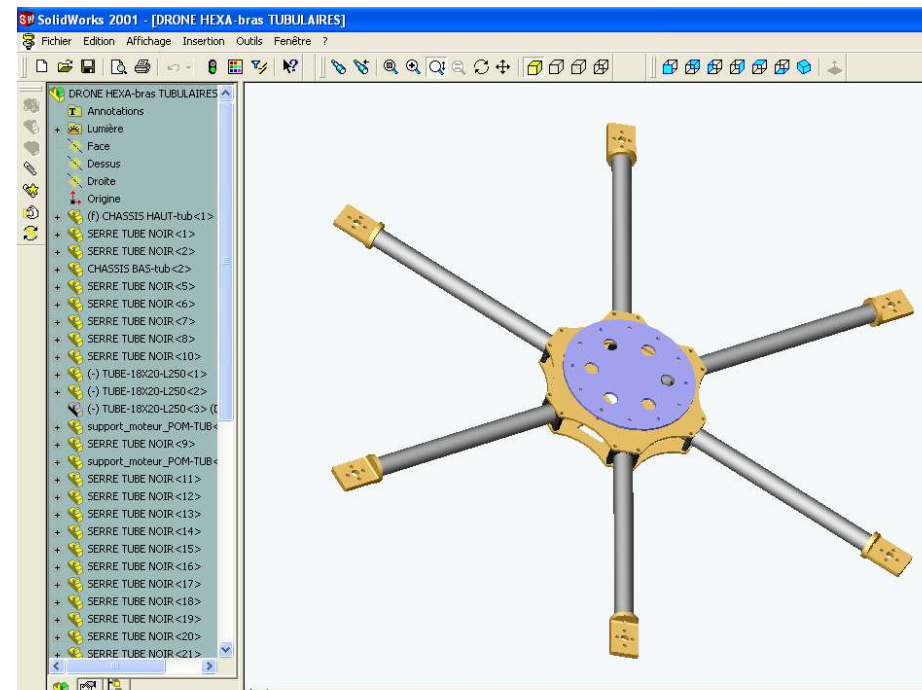
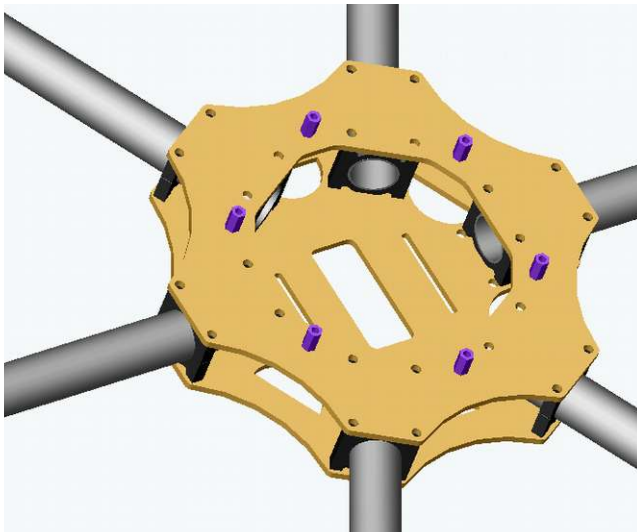

> conception + réalisation châssis drone

Quelle valeur ajoutée à l'utilisation de drone en milieu scolaire ?

Approche pédagogique Originale / Ludique / Motivante

> conception châssis DRONE

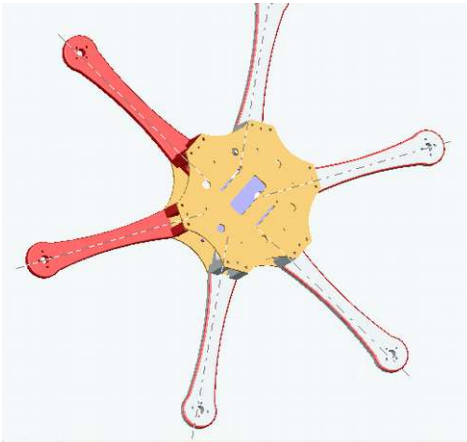

Choix des matériaux
Moyen de production

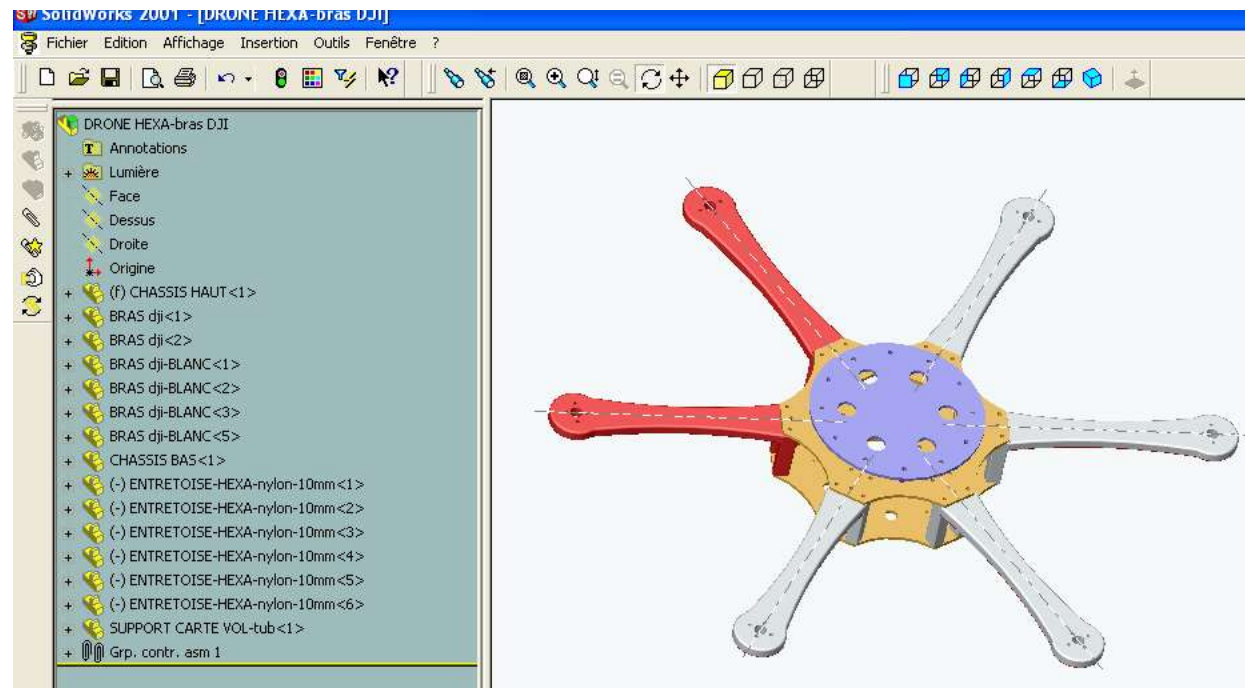

Ouissem Moussi

Enseignant de technologie
69800 Saint-Priest



Région académique
AUVERGNE-RHÔNE-ALPES

omoussi@ac-lyon.fr



COLLEGE
COLETTE 



RoboRAVE
SAINT-PIREST 
Robotics Education and Competition

Concours International
Ecole – Collège - Lycée

